

In order to ensure proper use and fault-free operation of the furnace, read this manual carefully.

1. Destination

The WA 33 universal oil heater is intended for heating the industrial rooms which are not included in the central heating system (workshops, car maintenance services, industrial halls, warehouses, inventory buildings, basements, garages, etc. The furnace may operate with the use of most mineral and plant oils such as, for instance, engine oils, fuel oils, gear oils, hydraulic oils, oils of HBO I, II, III type with the maximal kinematic viscosity of 6.00 mm²/s at the temperature of 20°C, flash-point temperature not lower than 40°C and thickness not less than 0.94 g/cm³.

Due to the local regulations, it is recommended to apply the diesel oil, fuel oil or biodiesel oil.

**DO NOT APPLY TRANSFORMER OILS
THEY MAY CONTAIN SUBSTANCES DETRIMENTAL TO THE OPERATION OF THE
FURNACE**

2. Environmental storage conditions

The WA 33 universal oil heater should be stored in the following conditions:

- temperature -20..85°C
- relative humidity 5..85%
- pressure 800..1200hPa
- dust-free
- environment free from chemical pollution.

3. Environmental conditions of use

The WA 33 universal oil heater should be used in the following conditions:

- temperature 0..30°C
- relative humidity 5..85%
- pressure 800..1200hPa
- protection level against the environmental impact IP20
- good ventilation of the heated room.

4. Characteristics of the controller

- possibility to adjust the furnace power within the range of 22 and 30 kW,
- protection of the furnace against overheating,
- protection against oil overflow in the furnace,
- automatic maintenance of settings at the voltage decay,

5. Safety aspects

The WA 33 universal oil heater is supplied from the 230V, 50Hz alternating current mains. A fuse with a fuse-element (1A, 250V) has been installed on the housing of the control module. The replacement of this fuse should be carried out unconditionally when the external power supply of the system (230V AC, 50Hz). is cut-off.

The WA 33 universal oil heater is equipped with two bimetallic sensors ensuring safe and economical operation of the device.

The bimetallic sensor placed in the furnace chamber reacts by opening contacts, when the temperature drops below 35°C. In the emergency situations (overheating, oil overflow) the processor checks the signal from the bimetallic sensor and switches on the exhaust fan until the furnace is cooled off to the temperature below 35°C.

The second bimetallic sensor is placed nearby the air supply fan, its threshold temperature is 90°C. Opening of its contacts, in consequence of exceeding the threshold temperature, causes immediate switching of the furnace into the *Overheating* mode (see section 8 of this manual).

The heater is equipped with a balance sensor placed below the overflow tank (the so called, overflow fuse).

Filling this tank causes immediate switching of the furnace into the *Overflow* mode (see section 8 of this manual).

The connection of the control panel of the furnace with other elements of the system (sensors, pump, fan) is made by the manufacturer, in the course of the normal operation, due to the operation safety, it is absolutely not allowed to interfere in any way in the covered and sealed part of the furnace controller and to infringe on the integrity of conductors. Any action of an unauthorised person creates a risk of exposure to the electric shock (230V AC, 50Hz) and burning.

6. Structure of the device

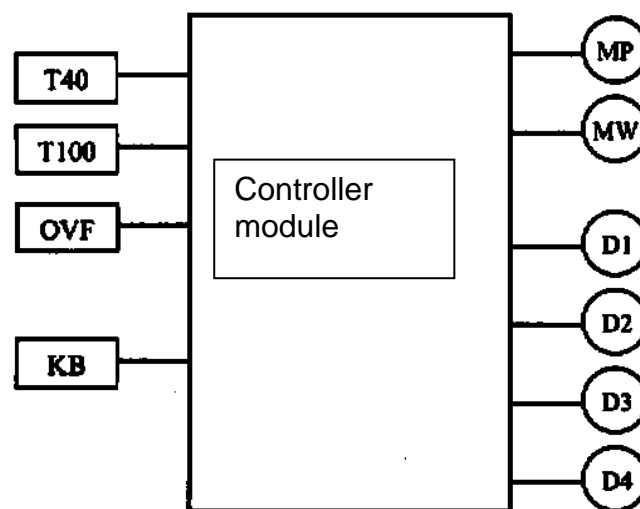

Fig. 1. Block diagram of the WA 33 universal oil heater

Notations:

T40	bimetallic furnace temperature sensor
T100	bimetallic safety sensor (STB)
OVF	overflow fuse
MP	pump (power 48W [230V AC, 50Hz])
MW	fan (power 35W [230V AC, 50Hz], capacity - 1000 m ³ /h)
KB	keyboard
D1	furnace overheating indicator
D1	overflow tank overfilling indicator
D3	pump motor revolving speed indicator
D4	furnace off/on indicator

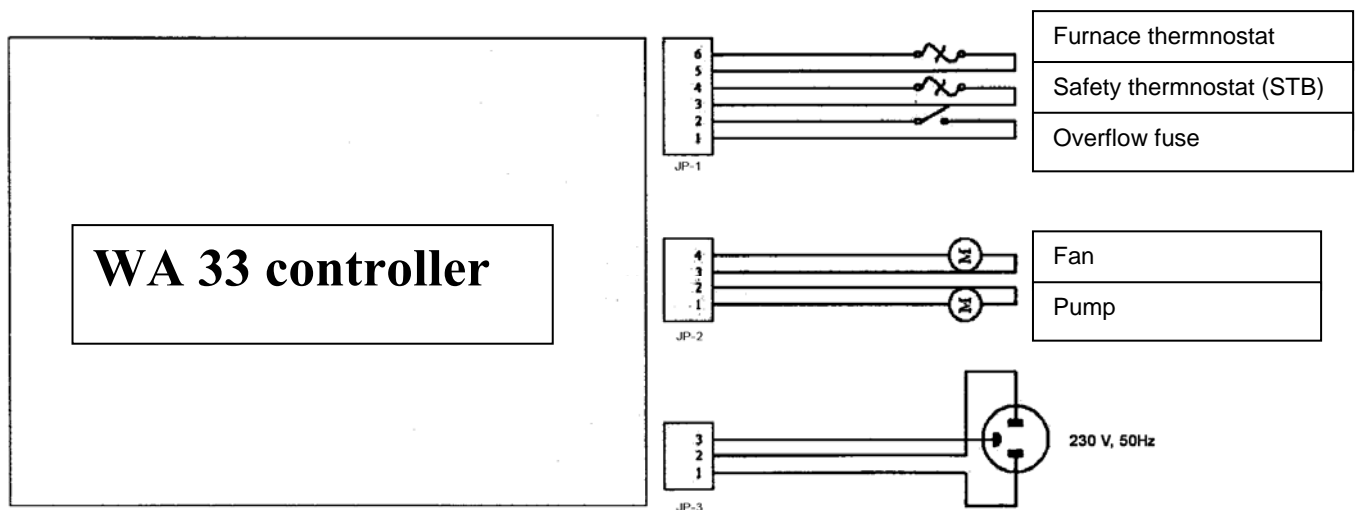

Fig.2. Furnace controller –group of conductors

7. Installation of the device

- during the installation of the device, meet all the local regulations, including the regulations referring to the national and European standards
- place the furnace on a flat concrete ground
- level the device. In order to check whether the heater is levelled, place the furnace pan in the lower part of the combustion chamber and pour a small amount of diesel oil on it. The oil should spread accurately in the middle of the pan.
- mount the stabiliser on the pipe coming out from the combustion chamber in order to ensure stable draught during the heater operation.
- in order to ensure the optimal draught, install a vertical chimney pipe (**not made of aluminium**) which is at least 6 meters long, smooth, resistant to high temperature
- check the leakproofness of all connections, in case of emergency, use the insulation tape for the purpose of sealing them
- make sure that the combustion pan is placed in the central part of the combustion chamber
- place the top ring inside the combustion chamber – the edging in the middle of the ring is placed upwards, - and mount an afterburner cylinder on it (hot air pipe)
- check the mains voltage (220-240V/50Hz) and connect the furnace to power supply, neither the fan nor the pump should be started as the furnace has not been switched on yet and no heat has been produced.
- maintain a safe distance from inflammable materials

The air exhaust fans operating in the same room or space as the device may introduce disturbances.

Assembly of the chimney pipe

In order to ensure proper burning, it is necessary to provide the properly made chimney installation. The following recommendations must be met while providing this installation:

- minimal pipe diameter: 150mm
- check the leakproofness of connections between the chimney elements
- minimal chimney height: 6m
- the section of the chimney inside the chimney should be insulated (dual wall)
- the wind should freely blow around the chimney outlet from all directions (the end of the chimney pipe should be above the roof top)

- if possible, all the chimney section should be vertical – avoid horizontal sections as well as bends of the chimney pipe, if necessary (e.g. two bends in case the pipe is run through the wall or window, then the maximal deflection angle amounts to 45°, the minimal chimney height should be increased up to 7m
- the minimal chimney flue draught 16Pa at nominal heating power
- the device may not be connected to the joint exhaust fumes discharge system

NOTE

Mounting the exhaust fumes discharge system, it is recommended to avoid horizontal sections of the chimney pipe system. In order to ensure the free gas outflow, the angle of the possible pipe bend should not be greater than 45°. The chimney outlet must be higher than the roof top.

The places where it runs through the ceiling, walls or roof must be insulated to avoid fire hazard. It is recommended to use the dual wall insulated chimney pipe in all places where there is a possibility of the touch contact, as well as outside the building, to ensure good draft and prevent condensation. Do not place any materials nearby the furnace, even the non-flammable ones. Ensure permanent access or air, necessary for the proper combustion process.

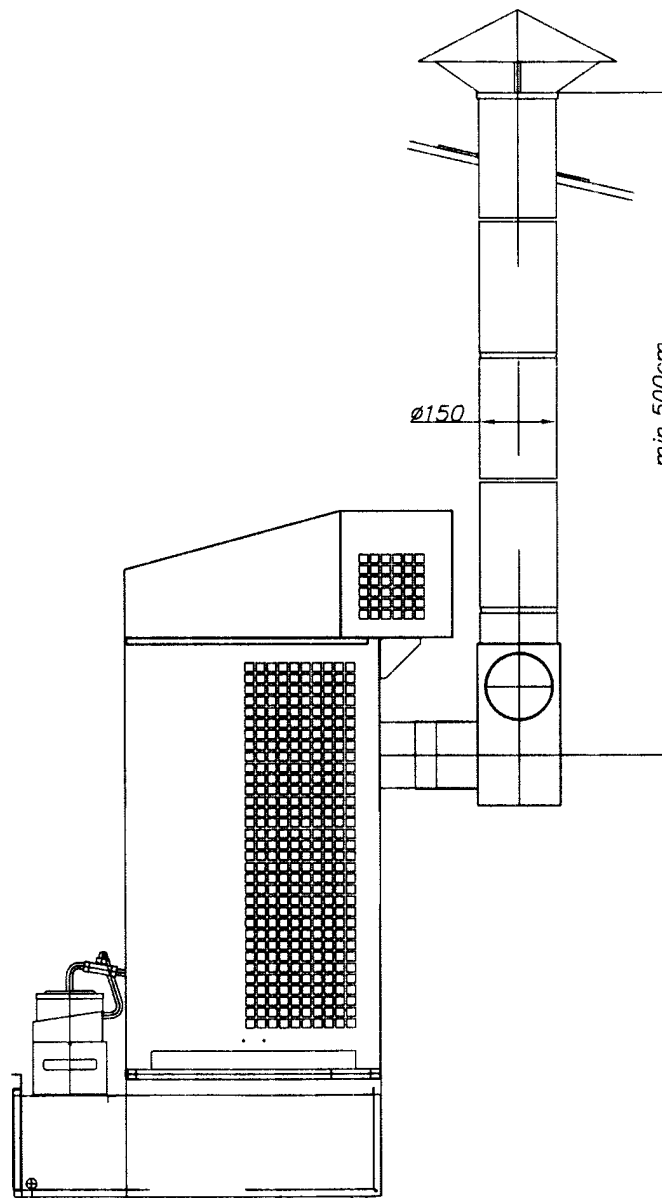

Fig.3. Chimney installation

8. Description of the operation of the device

Control panel

The controller of the WA 33 furnace for universal oil is equipped with four buttons which allow the user to control the operation of the heater, and four diodes signalling the state of operation of the device.

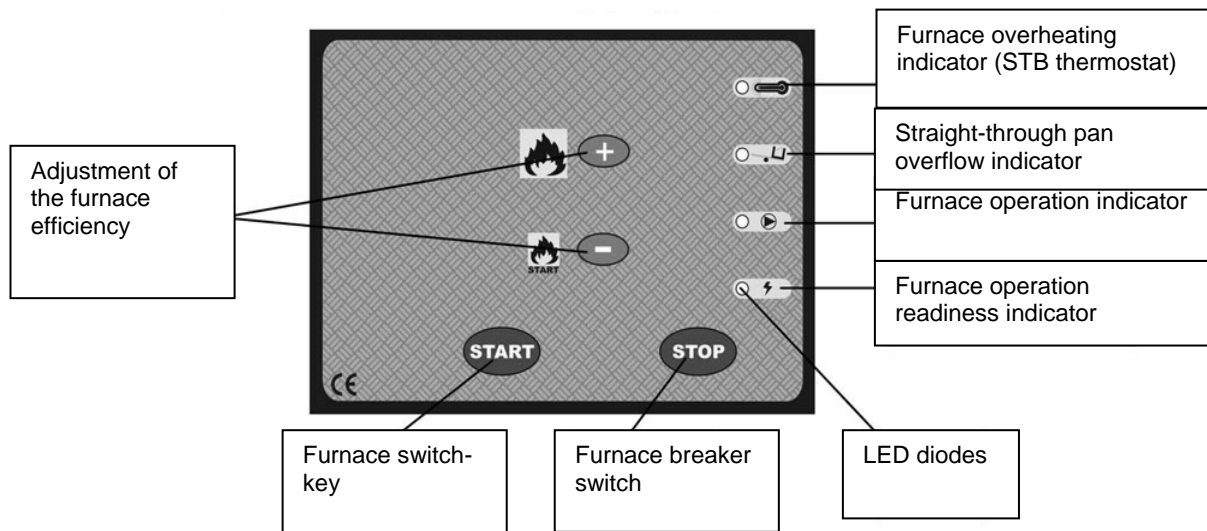

Fig.4. View of the front panel of the control module of the universal oil heater.

The following states characterise the operation of the device:

- Stop the device is ready for starting the operation
- Lighting off initial phase of the device's operation
- Operation proper operation of the device
- Damping emergency switching off
- Overheating emergency switching off
- Tank overflow emergency switching off

The heat is generated owing to burning the gas which is produced by oil heated to a high temperature. At the moment of connection of the device to the mains, it is in the readiness state (**Stop**) and no heat is produced, neither the fan nor the pump are operating. Pressing the *Start* button causes the green diode to be backlit and the furnaces switches to **lit off**. After the furnace is heated to the temperature of 40 C the contacts of the thermostat placed at the combustion chamber are closed, and oil supply pump and the air supply fan are switched on. It is signalled by the yellow diode, which is backlit on the control panel. Due to the smaller oil demand at the unheated furnace, the devices should operate on the first gear for at least 30 minutes (symbol on the panel „-,, means that the brightness of the light of the yellow diode is low). At this time, the pump for the furnace supplies about 1.85 kg/h of oil. After thirty minutes of operation, it is possible to switch on the second gear (the symbol on the panel is „+” which means that the brightness of the light of the yellow diode is greater). At the time operation on the second gear, 2.55kg/h of oil is supplied to the furnace.

The heater is switched off by pressing the *Stop* button on the control panel. At this moment, the pump is switched off (the yellow and the green diode are switched off on the control panel). The air exhaust fan

operates until the furnace temperature is below 35°C (**damping**). After the temperature reaches less than 35°C, the furnace returns to the **Stop** phase.

The furnace may be switched off automatically in the following cases:

- overheating of the combustion chamber
- overflow

The **overheating** signal is generated by the bimetallic sensor placed nearby the fan. The opening of the contacts is signalled by the exceeding the threshold temperature value. The control system switches off the pump (the operation indicator of the pump is not back-lit – yellow diode), the overheating state is signalled by the red diode, which is back-lit on the control panel. The air exhaust fan operates until the furnace temperature drops below 35°C. After reaching the temperature lower than 35°C, the furnace returns to the **Stop** phase.

After switching to the *Stop* phase (and even after switching off and then again switching on the power supply) the overheating signal is still back-lit. This enables the user to establish the cause of switching off the furnace.

In order to clear the overheating signal and return to the normal operation, wait until the furnace is cooled off (switching off the fan) and press the button placed on the housing of the bimetallic sensor. Then, press the *Start* button, which will cause the lighting of the diode signalling overheating to be switched off. The furnace may be restarted.

The **overflow** signal is generated by a mechanical sensor placed under the overflow tank. The opening of the contacts signals overflowing the tank. At the same time, the pump is switched on – the pump operation indicator is not back-lit anymore (yellow diode) and instead, the relevant red diode signifying the overflowing is back-lit. The air exhaust fan operates until the furnace temperature below drops below 35°C. After reaching the temperature lower than 35°C, the furnace returns to the **Stop** phase. Empty the overflow tank, and press the *Start* button, which will cause the (red) diode, which signals overflowing, to be switched off. The furnace may be restarted..

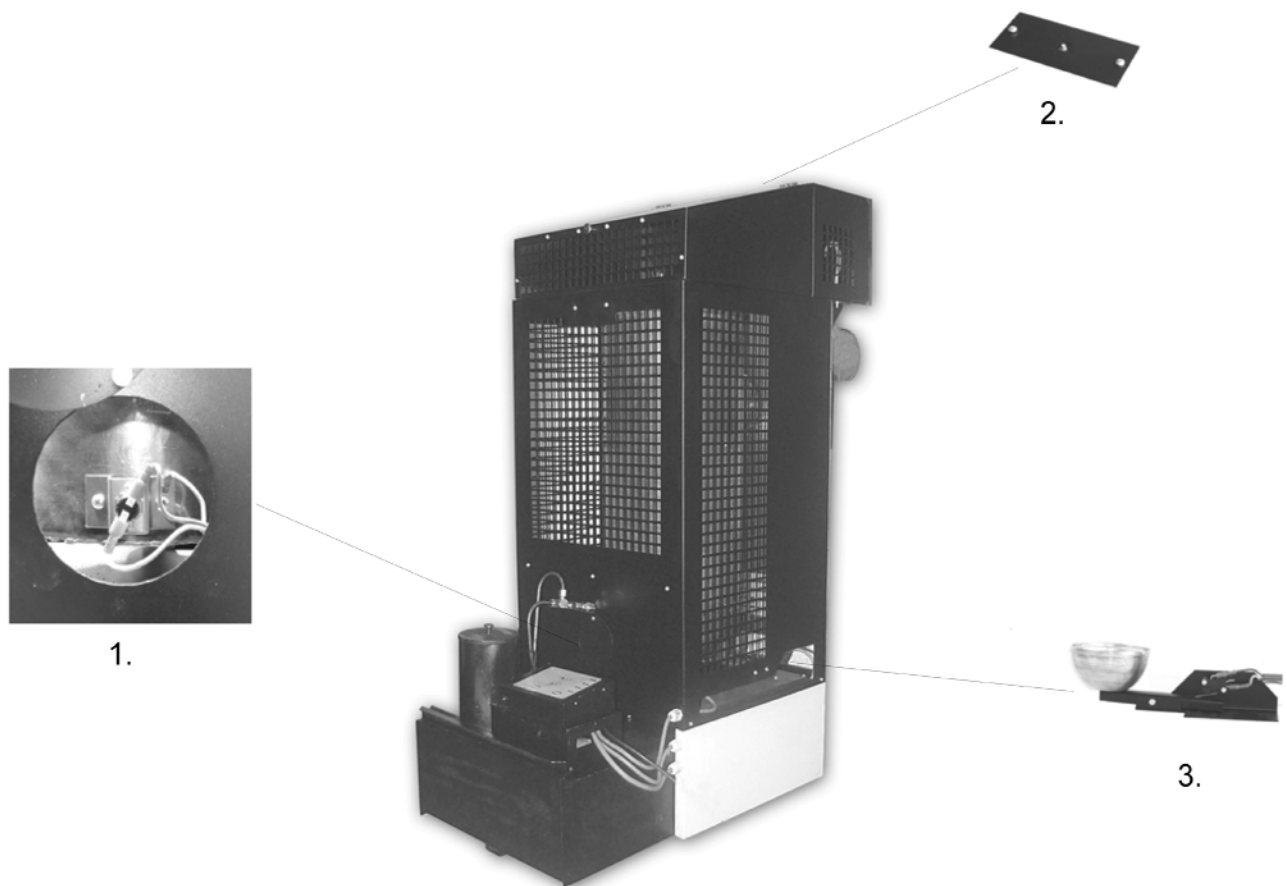

Fig.5. Placement of elements protecting the heater:

9. Operation of the heaters

NOTE

YOU MUST NOT ADD OIL TO THE FURNACE AND FIRE IT WHEN THE CHAMBER OR PAN OF THE FURNACE IS STILL HOT!!! ALWAYS WAIT UNTIL THE BURNER PLATE IS TOTALLY COOLED OFF. FAILURE TO OBSERVE THE ABOVE-MENTIONED RECOMMENDATION CREATES A RISK OF UNCONTROLLED IGNITION OF OIL VAPOURS AND BURNING!!!

Starting the device

After the heater, it goes through the respective operating conditions depending on the settings introduced by the user and the information received from the sensors attached to the controller system.

- in case of emergency, discharge the water from the fuel tank and fill it in with used oil
- put the plug of the power cable into the mains socket (230V 50Hz)
- open the top part of the heater housing and remove the cover of the combustion chamber, then take out the cylinder and ring (in the case of necessity, clean the combustion pan and base on which it is placed, but also the whole combustion chamber with a sleeve and the ring)
- check whether the furnace pan is cool and clean, then pour about 250 ml of fuel oil or diesel oil
- fire the oil, using a piece of paper which is crumpled into a ball for this purpose. the piece of paper must be set afire and thrown onto the furnace pan
- mount the ring and the cylinder, place the combustion chamber cover, close the top part of the heater housing
- press the *Start* button on the control panel (a green diode will be back-lit)
- after about 10-15 minutes, depending on the room temperature, the fuel pump and the fan will be switched on, and at the same time, the yellow diode for pump operation will be back-lit, the furnace will start to operate on the first gear with a decreased efficiency (22 kW; burning 1.85 kg/h), it may operate continuously in this condition, the second gear with an increased efficiency (30 kW: burning 2.55 kg/h) may be switched on (marked with "+" symbol) after 30 minutes from the start of the operation of the furnace.

Each pressing the Stop button and pressing the Start button again and again during its operation will cause the furnace to be lit off.

Switching off the device

- press the Stop button on the control panel (the yellow diode is not back-lit anymore), the pump stops supplying fuel on the combustion pan, the fan operates until the furnace is cooled off.

Do not connect the device to the mains, when the fan is in operation, wait until the furnace is cooled off. The furnace is switched off automatically. Remember that after the device is switched off, the cast-iron pan still maintains the higher temperature for some time (depending on the ambient temperature) and it is not allowed to switch on the furnace until it is cooled off

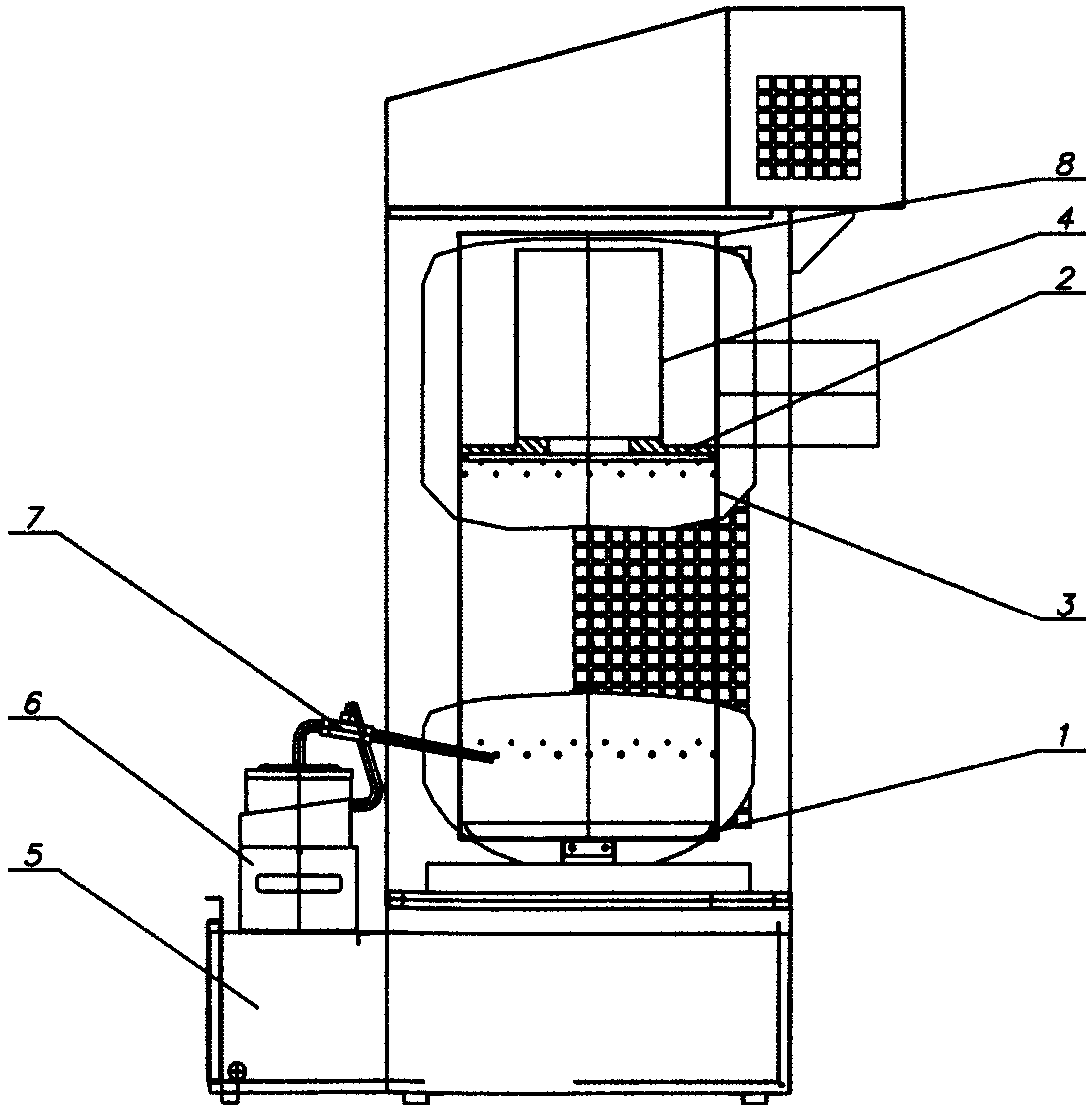

Fig.6. Structure of the heater

1. combustion chamber base
2. Ring
3. combustion chamber
4. Cylinder
5. Fuel tank
6. Pump and controller
7. Oil supply conduit
8. Furnace chamber cover

Maintenance

The heater requires little maintenance activities. The observance of manufacturer's recommendations will ensure fault-free and safe operation of the device.

- clean the furnace pan and the elements of the combustion chamber (cylinder, ring and cover) everyday
- check the overflow conduit is jammed or not (the conduit in the lower part of the combustion chamber, directly over the overflow tank), clean if necessary
- clean the furnace base in the combustion chamber (the element under the furnace pan) at least once a week
- check if the air inlet openings are not covered in the bottom and the top part of the combustion chamber
- clean the conduit supplying oil onto the furnace pan, the maximal time of operation of the furnace pan without cleaning amounts to about 7-14 hours (depending on the applied oil for combustion)
- during the heating season, clean the fuel tank and the oil pump filter
- if the furnace is inoperable for a longer period of time, clean the combustion chamber and the daily tank accurately, then protect them from corrosion coating them with a thin layer of oil

IT IS RECOMMENDED TO PERFORM PERIODICAL CHECKS AT AN AUTHORISED SERVICE

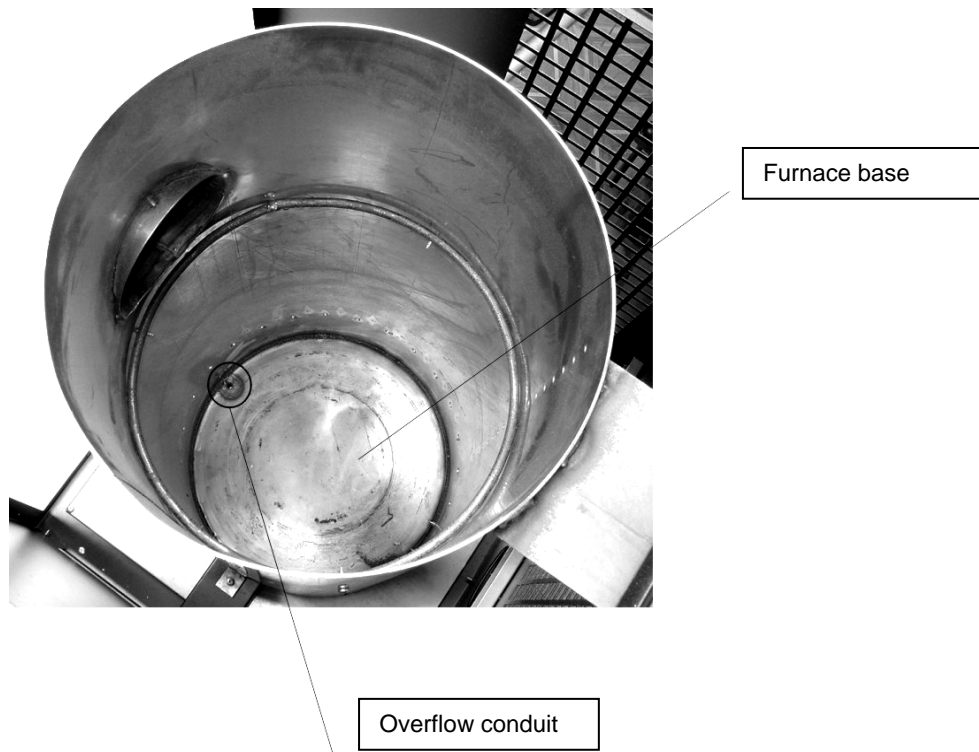

Fig.7. Combustion chamber

10. Repair of defects

In the case of the failure of the device, the list below may help in locating the defect. In general, its removal is simple. The most frequent problems are listed below. The digits signify the possible causes. The order of the digits expresses the probability of occurrence of the defect.

NOTE:
Before starting any activities, pull the plug out of the mains socket.

DEFECT	CAUSE
The pump does not commence operation and the pump operation control is not lit	6-3-7
The flame is put off and the pump is still in operation	2-5-9-10-12
The combustion chamber rumbles.	10-11-12
There is soot in the combustion chamber and in the chimney	8-9-10-11-12
The non-burnt oil remains on the combustion plate.	8-9-11-12 or there is too much diesel oil at the start-up

No.	CAUSE	METHOD OF REMOVAL
1	Lack of power supply.	<ul style="list-style-type: none"> • Check whether the plug is in the socket and check the fuses
2	Water or deposit in the tank.	<ul style="list-style-type: none"> • Clean the tank and the filter
3	The pump motor cannot be switched on	<ul style="list-style-type: none"> • Check the STB and the overflow protection
4	The motor and the pump are not operable	<ul style="list-style-type: none"> • The fuel is too dense or too cold. Dissolve it with diesel oil • Check the pump operation control thermostat and replace it if necessary. • Check the motor and see whether the pump is not dirty inside. • Check the STB and the overflow protection
5	The fuel conduit is clogged, the oil returns to the tank by means of the return conduit	<ul style="list-style-type: none"> • Clean the fuel conduit or replace it, if necessary
6	The thermostat of the pump operation control has not reached the right temperature	<ul style="list-style-type: none"> • Wait until the furnace cools off and restart it • Replace the thermostat
7	Overflow protection is full	<ul style="list-style-type: none"> • Clean it
8	The safety thermostat (STB) does not operate correctly or does not operate at all	<ul style="list-style-type: none"> • Reset the thermostat • Replace it
9	Insufficient combustion air inflow	<ul style="list-style-type: none"> • Clean the openings of the furnace chamber • Check the proper operation of the fan
10	Improper flue draught	<ul style="list-style-type: none"> • Check whether the chimney pipe is mounted in accordance with the recommendations entitled „Mounting the chimney flue” • Check the leakproofness of the chimney system • Clean it, if necessary
11	The flue draught is too strong or too variable	<ul style="list-style-type: none"> • Mount the flue draught stabiliser and regulate it to minimum 2 mm W.C. (16 Pa).
12	The flue draught is too weak	<ul style="list-style-type: none"> • Check all the connections • Decrease the number of bends • Extend the chimney • Insulate the chimney pipe outside the building • See all the information regarding the chimney flue in the manual.